

# Paper & Image Estimator

## How to Estimate Your Volumes of Images

During any document copy, scanning or microfilming project the largest cost will be the per document or per image cost. The following should help you create a preliminary estimate of the number of documents your organization has for copy, scanning or microfilming. These are the same guidelines that QAI uses when estimating a price quote. We have made them available, so you can better estimate your own volume.

### Standard Document Storage



Unbound Paper  
150-175 Pages Per Inch



Standard File Box  
2,000 - 2,500 Pages Per Box



Banker Style Boxes  
4,500 - 5,000 Pages Per Box



Vertical File Cabinet  
3,500 - 4,000 Pages  
Per Drawer



Open Shelving  
1,500 Pages Per  
Horizontal Foot



Lateral File Cabinet  
5,500 - 6,000 Pages  
Per Drawer



Color Photos  
100 - 120 Photos  
Per Inch



Engineering Drawing  
(unfolded)  
125 - 150 Sheets Per Inch

# Paper & Image Estimator

## How to Estimate Your Volumes of Images

During any document copy, scanning or microfilming project the largest cost will be the per document or per image cost. The following should help you create a preliminary estimate of the number of documents you have for copy, scanning or microfilming. These are the same guidelines that QAI uses when estimating a price quote for you and we have made them available to you, so you can better estimate your own volume.

### Popular Bound Document Storage



1" Binder  
250 - 275  
Pages Each



2" Binder  
450 - 480  
Pages Each



3" Binder  
650 - 670  
Pages Each



4" Binder  
750 - 780  
Pages Each



5" Binder  
950-1050  
Pages Each



2-Hole 1" Binder  
225 - 240  
Pages Each



2-Hole 2" Binder  
450 - 480 Pages  
Per Inch

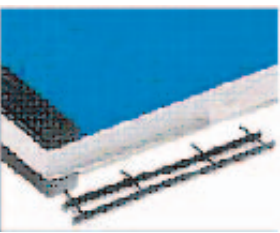

Velo Binder  
200 - 300 Pages  
Per Each



Plastic Coil/Spiral Binder  
175 - 200 Maximum  
Pages Each

# Paper & Image Estimator

## How to Estimate Your Volumes of Images

During any document copy, scanning or microfilming project the largest cost will be the per document or per image cost. The following should help you create a preliminary estimate of the number of documents you have for copy, scanning or microfilming. These are the same guidelines that QAI uses when estimating a price quote for you and we have made them available to you, so you can better estimate your own volume.

### Microfilm Types & Estimating Images



#### Image Reduction

Popular Filming Reductions	Approximate Image Size
24x	9.0mm wide & 11.5mm tall
31x	7.5mm wide & 9.5mm tall
42x	5.0mm wide & 6.5mm tall
There are other reductions, such as: 19x, 36x, 48x, or 54x, but the above are most common.	

#### Film Polarity

Negative Film	Positive Film
---------------	---------------

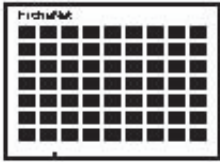
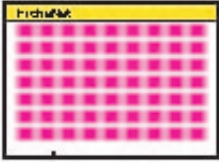
#### Masters or Duplicates?

105mm Master Microfiche	105mm Duplicate Microfiche
Identify by: No Color Stripe at the top of the film images . ALWAYS B/W on clear film.	Identify by: Color Stripe at the top of the film & images can be blue in color.
	
16mm Master Rolls	16mm Duplicate Rolls
Identify by: Images always black, thicker film & usually in a black plastic or paper film box.	Identify by: Blue images, thin film, loaded into a C-Clip, 3M style or other type of cartridge.
	

# Paper & Image Estimator

## How to Estimate Your Volumes of Images



During any document copy, scanning or microfilming project the largest cost will be the per document or per image cost. The following should help you create a preliminary estimate of the number of documents you have for copy, scanning or microfilming. These are the same guidelines that QAI uses when estimating a price quote for you and we have made them available to you, so you can better estimate your own volume.

### Microfilm Types & Estimating Images Continued...

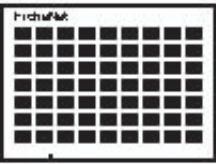
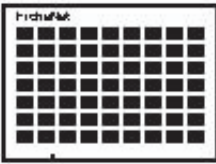
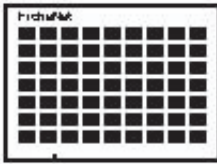
#### Microfiche Images Per Fiche/Jacket

		
<b>Step &amp; Repeat Microfilm</b>	<b>Jacketed Microfilm</b>	<b>COM Microfilm</b>
Identify by: Images are cleanly spaced & images are generally straight & clean. Can contain portrait & landscape docs.	Identify by: Plastic sleeves with strips of 16mm film inserted into 5 or 7 horizontal pockets & a typewriter style title.	Identify by: Images are perfectly straight, all the same size & evenly spaced very tightly & contain rows.
Multiply Rows & Columns for an image count.	Multiply Rows & Columns for an image count.	Multiply Rows & Columns for an image count.

#### 16mm Images Per Roll

		
16mm Rolls - 24x Reduction	16mm Rolls - 31x Reduction	16mm Rolls - 42x Reduction
Labels usually report the number of images. Approx. 2,000 - 2,400 8.5" x 11" images per 100' roll.	Labels usually report the number of images. Approx. 2,500 - 2,800 8.5" x 11" images per 100' roll.	Labels usually report the number of images. Approx. 4,000 - 4,300 8.5" x 11" images per 100' roll.

#### 35mm Aperture Cards

<b>Aperture Cards</b>
125 - 135 Cards Per Inch